

CITY OF AUBURNDALE

JACK & BORE DETAILS

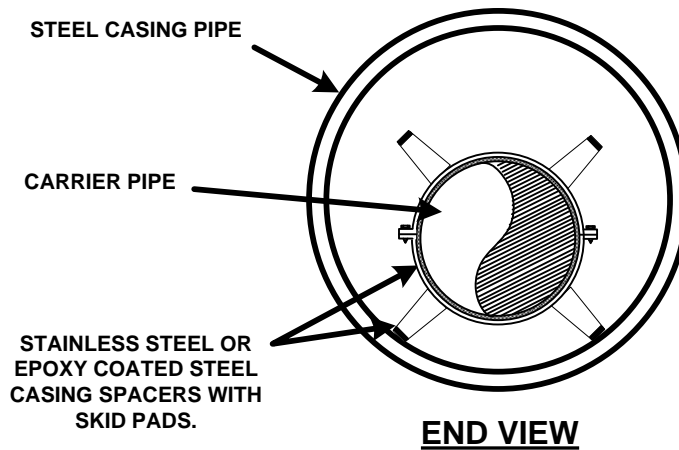
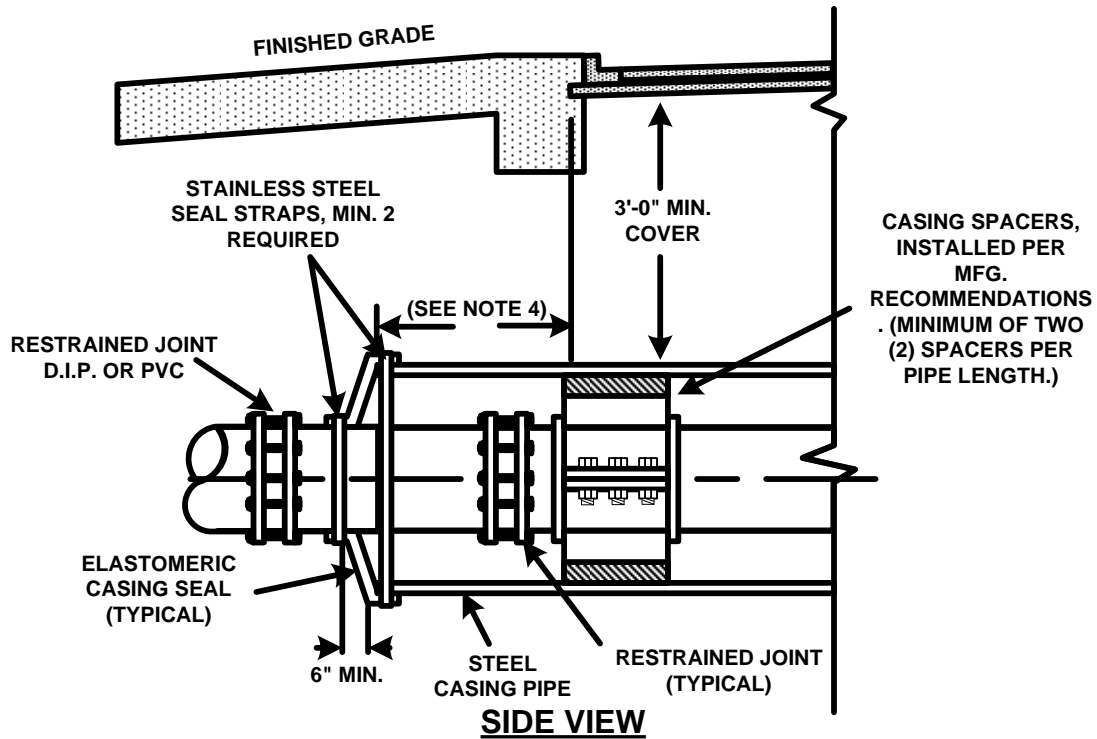

NOTES:

1. WHEN CONSTRUCTION IS WITHIN FDOT JURISDICTION, ADDITIONAL REQUIREMENTS OF THE UTILITY ACCOMMODATION GUIDE SHALL BE MET.
2. CASING SPACERS ARE REQUIRED, WOOD SKIDS ARE PROHIBITED.
3. LARGER SKIDS SHALL BE REQUIRED FOR PIPE GREATER THAN 24" DIAMETER.
4. WHERE PRACTICAL, CASING SHALL EXTEND 10' BEHOND EDGE OF PAVEMENT AND SHALL NOT BE LESS THAN 6' BEYOND EDGE OF PAVEMENT IN ANY CASE. THE COUNTY MAY REQUIRE LONGER CASING FOR DEEPER BORES.
5. ALL SKID PADS SHALL FIRMLY TOUCH CASING FOR GRAVITY PIPE APPLICATIONS.