

CITY OF AUBURNDALE SEWER MANHOLE RING & COVER DETAILS

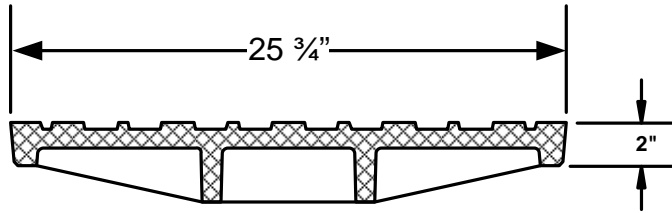

(2) NON-PENETRATING PICK HOLES

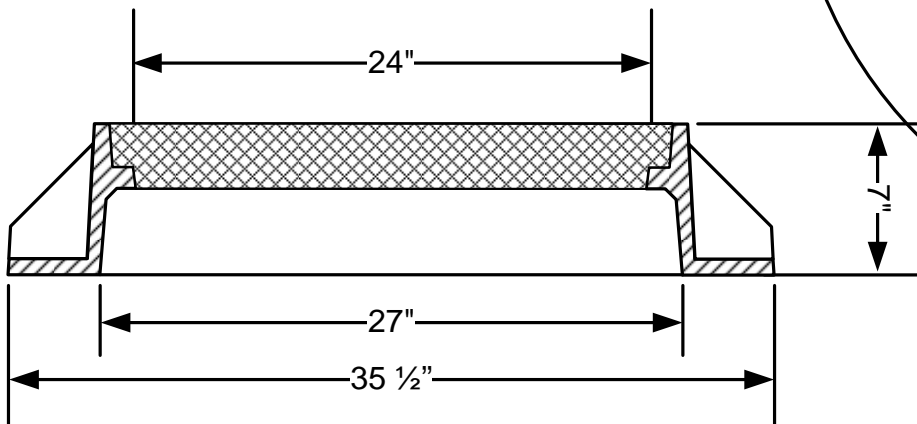
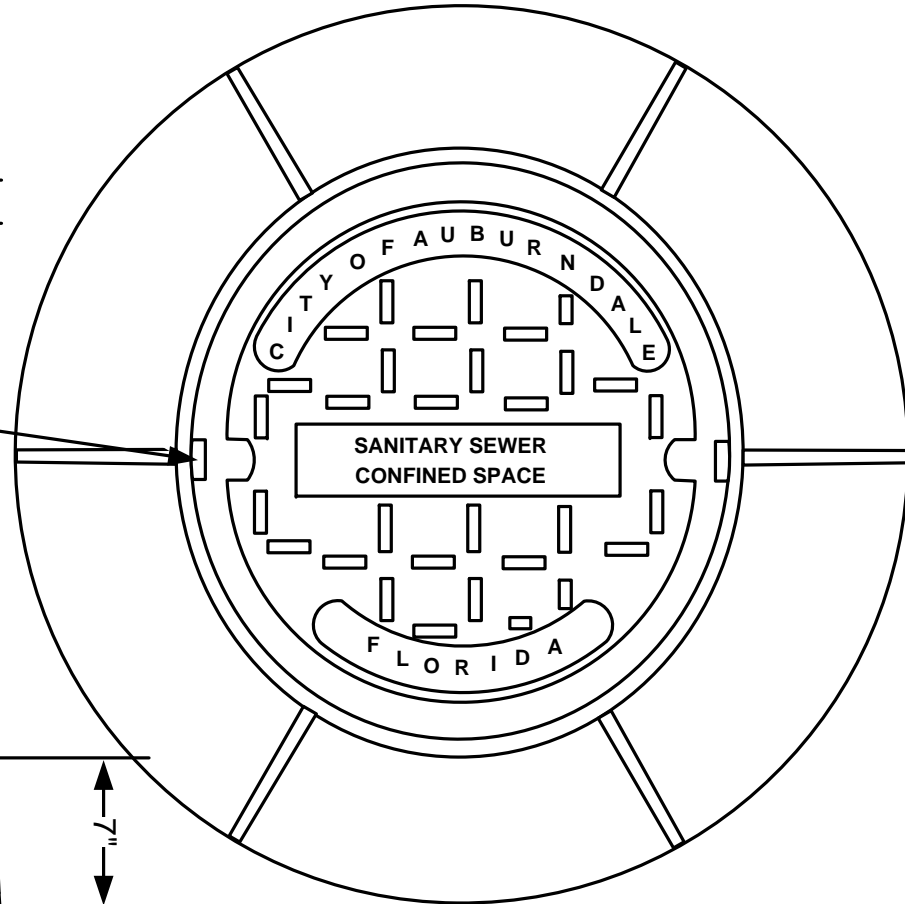

NOTES:

- 1- MATERIAL: ASTM-A48 CLASS 30B GRAY IRON
- 2- RING WT: 220 LBS. APP.
- 3- COVER WT: 190 LBS. APP.

U.S. FOUNDRY & MFG. CORP.
MEDLEY, FLORIDA

USF 227 RING & AS COVER

DWN. BY: DBB	SCALE: 1/8"=1"	DATE: 8/12/98
CHK. BY:	DWG. NO: A0136	REV: